

ZGLA1 Anchor 1"

INSTALLATION,
MAINTENANCE & SERVICE

STEP & IN GROUND | Anchor Series | 1" dia.
1.7W (150lm) | 12V | HK LED



Materials

Machined from solid 360 brass
316 stainless steel hardware

Dimming

MLV / ELV



TURN OFF POWER BEFORE AND DURING WIRING TO POWER SUPPLY

Contents

Installation Applications

Softscape: Dirt, Mulch, Sand & Soil	Pg 2
Direct Structure: Pergolas, Posts, Decks	Pg 4
Hardscape: Pavers and Flagstone	Pg 5
Concrete: Pour-in-place	Pg 7
Thin Substrates: for Materials Thinner Than 0.9"	Pg 9

Adjustments

Optic & Optic Accessory Replacement	Pg 11
Shield Replacement	Pg 13

Wiring

LightingShrink®: Connectors Installation Instruction	Pg 14
--	-------

Softscape: Dirt, Mulch, Sand & Soil

MATERIALS & TOOLS REQUIRED

- ZGLA1 Anchor 1" Step & Marker Light
- Included PVC outer sleeve
- LightingShrink® connectors (preferred), or any UL-listed waterproof connector, or installer-preferred method
- Shovel
- Wire strippers
- Heat gun or Torch (for LightingShrink or other heat-shrink style connectors)

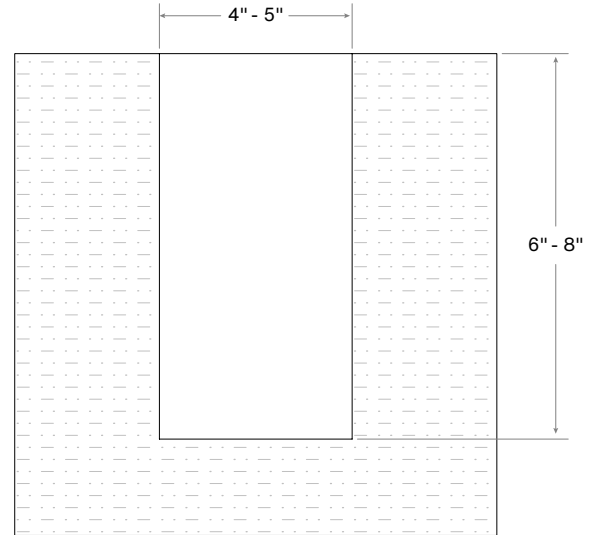

1 Excavate

- Dig a hole at the fixture location to a total depth of 6" to 8".

2 Prepare PVC Sleeve & Wire

- Feed the fixture's direct burial wire through the provided PVC sleeve. Orient the sleeve so that the fixture aligns with the flat side and the wire exits through the notched side (see diagram).

3 Prepare Branch Wiring

- Cut and strip branch wire (input power) and outbound wire (if part of an inline run).
- Strip insulation to 1/2" on each conductor.

4 Make Splice Connections

- Using LightingShrink (or other UL Listed waterproof connector) direct burial connectors, splice the fixture wire, branch wire, and outbound wire together.
- For details of LightingShrink install instructions consult last page of this installation document.

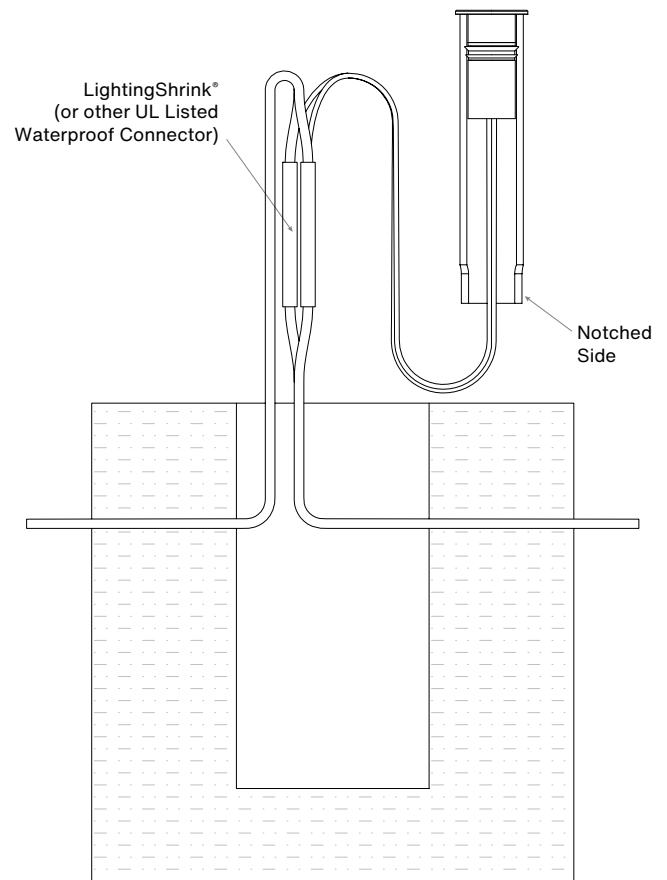

Softscape (Cont.)

5 Insert Fixture

- Insert the fixture into the PVC sleeve until it bottoms out on flat side of PVC.
- Align and level the fixture as required. Fixture top should be flush or slightly above grade. If below grade, remove the fixture and PVC sleeve, compact ground media, and reinstall.

6 Backfill

- Carefully backfill around the PVC tube and fixture with native soil.
- Compact lightly to stabilize the sleeve and prevent settling.

7 Test

- Power on the system to confirm the fixture operates correctly before completing final cleanup.

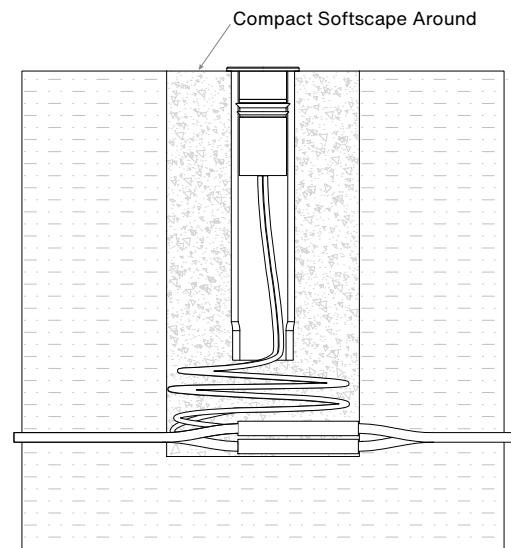
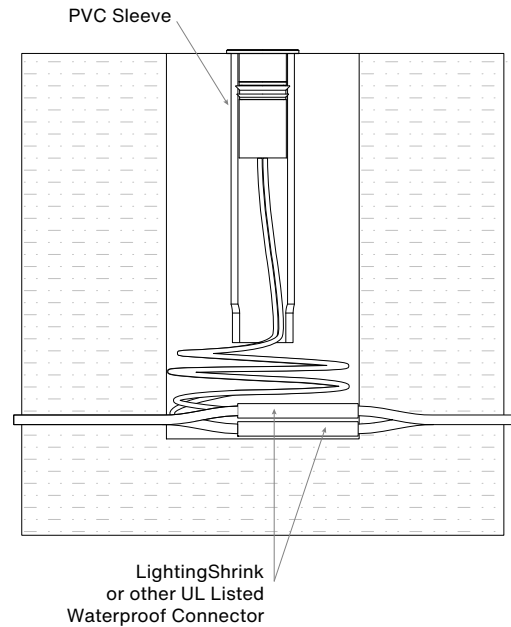

Direct Structure: Pergolas, Posts, Decks

MATERIALS & TOOLS REQUIRED

- ZGLA1 Anchor 1" Step & Marker Light
- LightingShrink® connectors (preferred), or any UL-listed waterproof connector, or installer-preferred method
- Drill with 1" hole saw or 1" paddle bit
- Wire strippers
- Heat gun or Torch (for LightingShrink or other heat-shrink style connectors)

1 Prepare Mounting Location

- Identify the desired fixture location on the structure (wood beams, pergola vertical or horizontal beams, wood decking, posts, etc).
- Drill a **1" diameter hole** at the marked location using a hole saw or paddle bit. The hole should be a through hole.

2 Feed Wire

- Feed ZGLA1 wire through the hole.

3 Prepare Branch Wiring

- Cut and strip branch wire (input power) and outbound wire (if part of an inline run).
- Strip insulation to 1/2" on each conductor

4 Make Splice Connections

- Using LightingShrink connectors, splice the fixture wire, branch wire, and outbound wire together.
- For details of LightingShrink install instructions consult last page of this installation document.

5 Insert Fixture

- Feed excess wire back through the 1" hole.
- Insert the fixture into the hole until it seats flush with installation surface.
- The fixture can be rotated if needed for desired aim and focus.

6 Test

- Power on the system to confirm the fixture operates correctly before completing final cleanup.

Beam, Post, Rafter

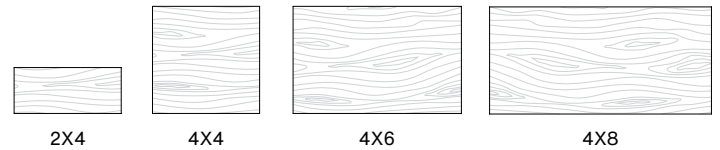

Drill with 1" Hole Saw

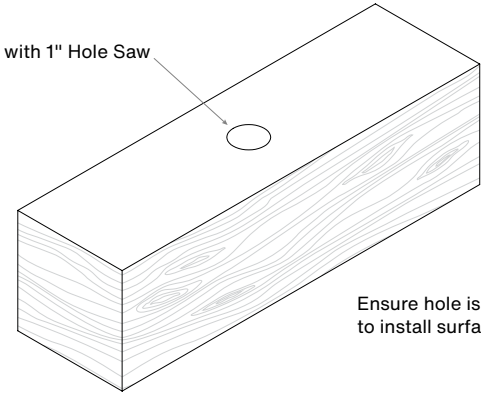

Ensure hole is perpendicular to install surface

TIP: A rough edge on the exit surface can hinder installation. It can be beneficial to chase the hole saw through the hole again to remove the rough edges.

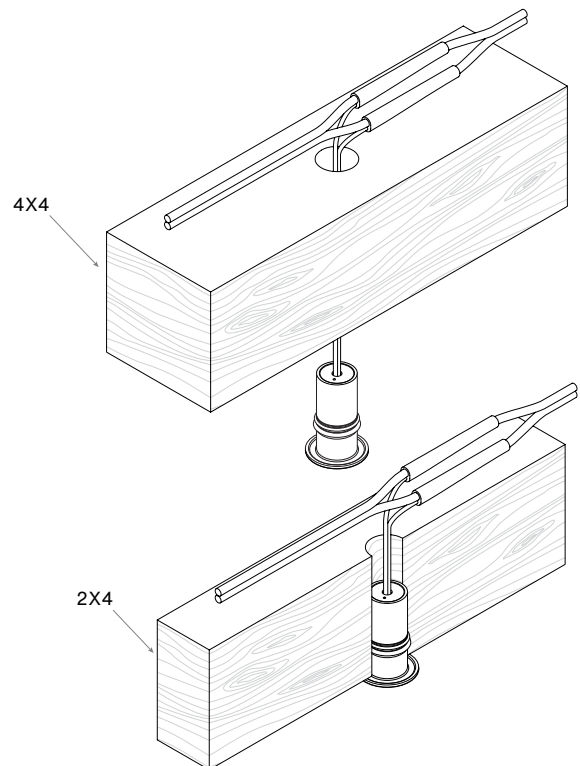

WARNING: If this product is installed in a building structure where insulation is in contact or adjacent to the fixture, the installer must use Class 2 cable and contact HK Lighting for the appropriate Class 2 (<60W) power supply.

Hardscape: Pavers and Flagstone

MATERIALS & TOOLS REQUIRED

- ZGLA1 Anchor 1" Step & Marker Light
- Included PVC outer sleeve
- LightingShrink® connectors (preferred), or any UL-listed waterproof connector, or installer-preferred method
- Customer-furnished 2" PVC coupler or 2" PVC pipe, cut to 3" length
- Wire strippers
- Heat gun or Torch (for LightingShrink or other heat-shrink style connectors)

1 Prepare Mounting Location

- Install compacted base material and paver leveling sand to local code requirements. Install direct burial wire below compacted base. Wire that is located below pavers is recommended to be installed into a 2" PVC sleeve to aid in future servicing if needed.
- Identify the desired fixture location in paver layout. Install pavers up to the paver location that will have a marker light.
- Drill a 1" diameter hole at the marked location using a diamond bit hole saw or concrete core bit. We suggest having at least 1" of paver material between light source and edge of paver so paver structure and strength is not compromised.
- Locally excavate a small area located **directly under the light source** location and place the 2" PVC coupler as show in diagram. This coupler will provide volume to place wire and splices.
- Compact base and/or sand back around PVC coupler, making sure coupler is secure and level with paver compacted base or leveling sand.

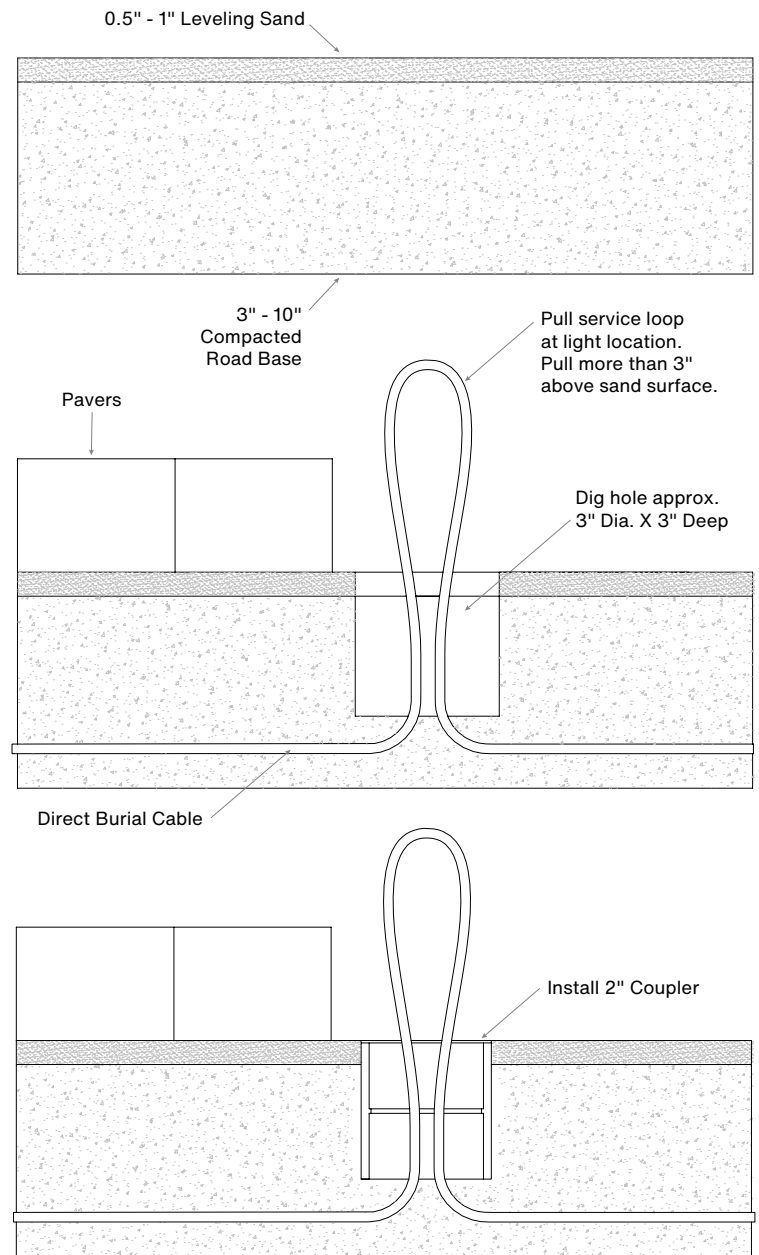

Drill hole with 1" bit/hole saw.

Ensure hole is perpendicular to install surface.

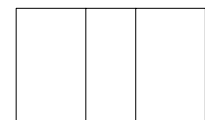

TIP: A rough edge on the exit surface can hinder installation. It can be beneficial to chase the hole saw through the hole again to remove the rough edges.

Hardscape (Cont.)

2 Feed Wire

- Branch and outbound wires should be routed up through the PVC coupler during paver base installation.
- Feed marker light wire through drilled paver hole, do not install paver yet. You should have ~30 inches of wire to work with on the back of the paver.

3 Prepare Branch Wiring

- Cut and strip branch wire (input power) and outbound wire (if part of an inline run).
- Strip insulation to 1/2" on each conductor. Making sure to not have more than 3" of branch or outbound wire above PVC Coupler. This reduces the wiring storage volume.

4 Make Splice Connections

- Using LightingShrink connectors, splice the fixture wire, branch wire, and outbound wire together. For paver installed we strongly recommend using LightingShrink connections and not waterproof wire nuts.
- For details of LightingShrink install instructions consult last page of this installation document.

5 Insert Fixture

- Once splice connections are made wrap excess wire into the wire void provided by PVC coupler or pipe.
- Insert the fixture into the core drill paver until it sits seats flush paver top surface, wrap excess fixture wire into wire void as you position paver down onto the compacted base and wiring cavity.
- The fixture can be rotated if needed for desired aim and focus.

6 Test

- Power on the system to confirm the fixture operates correctly before completing final cleanup.

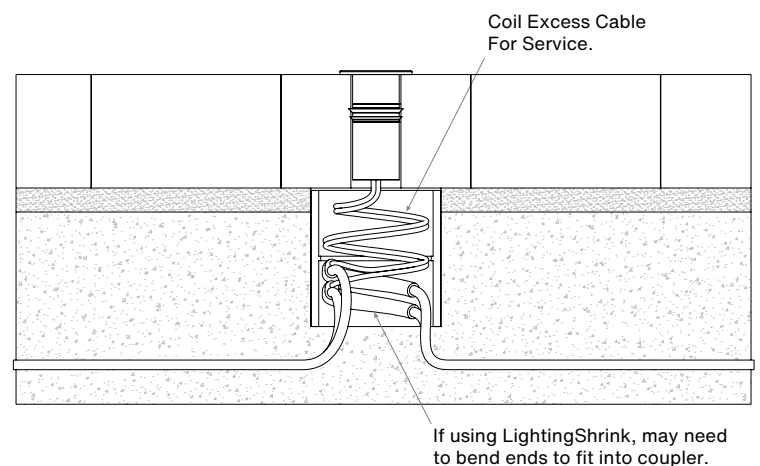
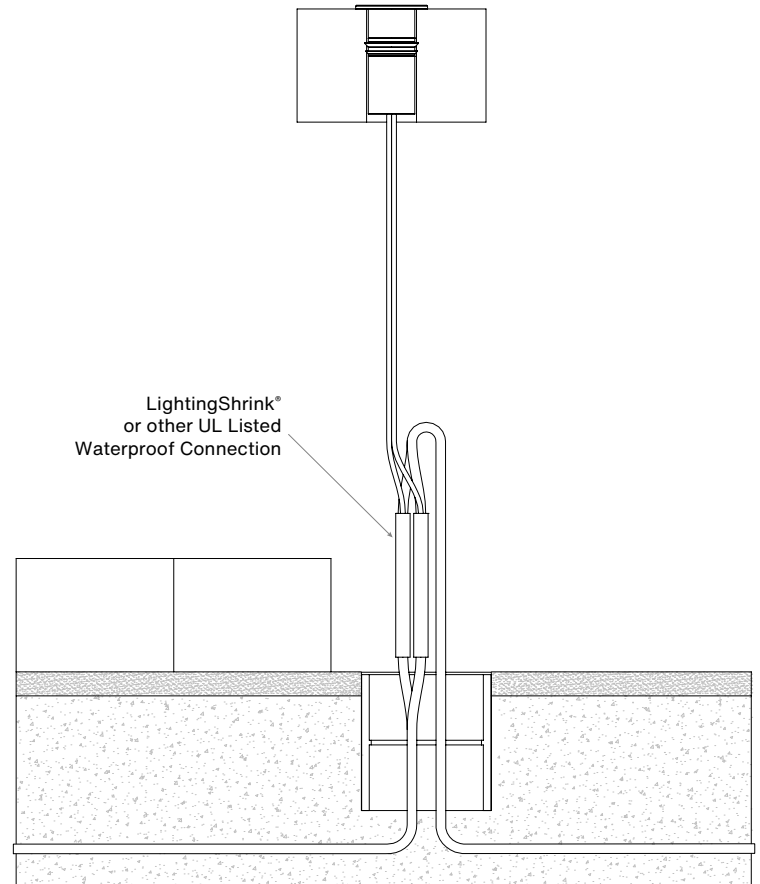

Concrete: Pour-in-place

MATERIALS & TOOLS REQUIRED

- ZGLA1 Anchor 1" Step & Marker Light
- Included PVC outer sleeve
- LightingShrink® connectors (preferred), or any UL-listed waterproof connector, or installer-preferred method
- Wire strippers
- Heat gun or Torch (for LightingShrink or other heat-shrink style connectors)

NOTE: A concrete pour junction box must sit below the fixture to facilitate wiring connections within the concrete pour zone.

1 Prepare Mounting Location

- Identify the desired fixture location within the concrete pour area.
- Install the included PVC sleeve or site-furnished 1" Schedule 40 PVC conduit vertically in compacted gravel or road base at the fixture location.
- Secure the PVC sleeve so it remains perpendicular to the finished concrete surface during the pour using installer-preferred methods (wire ties, staked rebar, etc.).

NOTE: A concrete pour junction box must sit below the fixture to facilitate wiring connections within a large scale concrete pour zone where the fixture is not near the border/perimeter of the concrete.

2 Feed Wire

- If wiring cannot be routed outside of the concrete form after the pour, feed branch wiring up through the PVC sleeve before concrete placement.
- Use a wire gauge that allows conductors to be pushed back into the 1" sleeve or customer furnished junction box without excessive force.
- Ensure sufficient slack exists for final splicing after the pour is complete.

3 Secure PVC Sleeve

- Secure the PVC sleeve per installer preference to prevent movement during concrete placement.
- Ensure the inside of the PVC sleeve remains clear of debris and free of damage.
- Plug or tape the top of the PVC sleeve prior to the pour to prevent concrete intrusion.

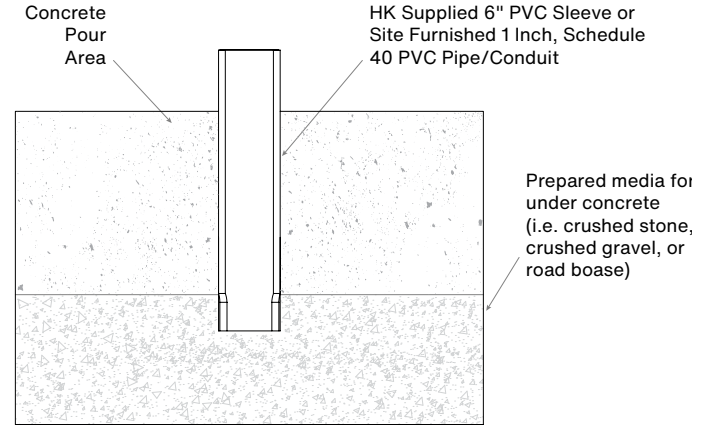

Using preferred method, secure PVC so that it will be perpendicular to finished surface.

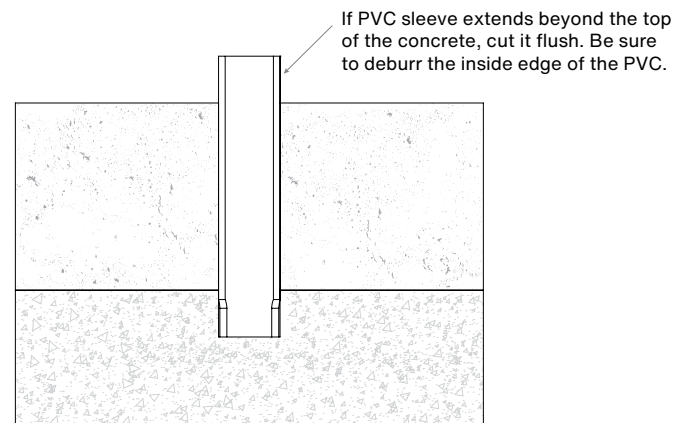
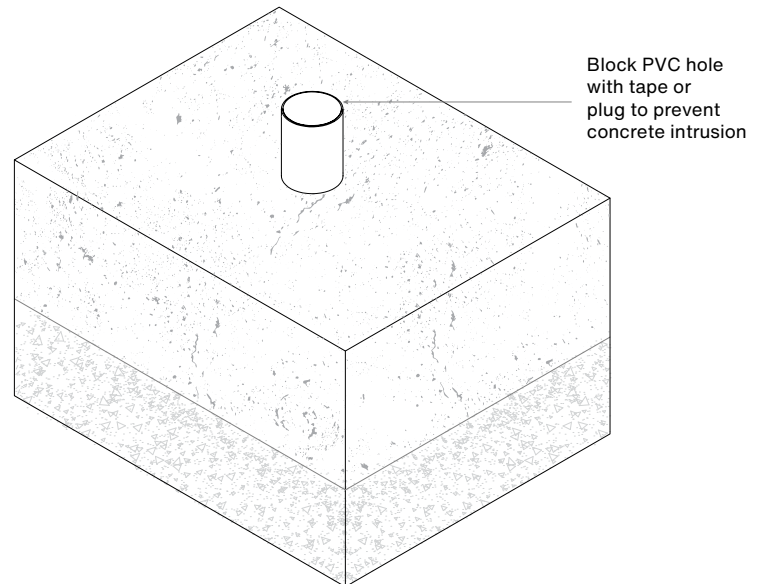

Concrete: (Cont.)

4 Prepare Sleeve After Pour

- Once the concrete pour is complete, confirm the PVC sleeve is flush and level with the finished concrete grade.
- If the sleeve extends above the concrete surface, cut it flush using an oscillating multi-tool. Deburr the inside edge of the PVC sleeve to prevent wire damage.

5 Route Wiring

- Feed the fixture wire down through the PVC sleeve.
- **For perimeter concrete installations (within 24" of slab edge):**
Route fixture wiring outside of the concrete envelope using a fish tap so all electrical connections remain accessible.
- **For interior concrete installations (greater than 24" from slab edge):**
Pull branch wiring from required concrete pour-rated floor box or vault up through the PVC sleeve to fixture wire.

6 Make Splice Connections

- Using LightingShrink® connectors (preferred) or other UL Listed waterproof direct burial connectors, splice the fixture wire, branch wire, and outbound wire together.
- Splices shall not be buried directly in or under concrete. All electrical connections must be located outside of the concrete envelope or within a concrete pour-rated junction box (interior pour locations only).
- For "interior" envelope installations where splices are located below the slab in a junction box, provide a **service loop of 3"-6" of extra wire** for future maintenance. Do not exceed this range.
- For LightingShrink installation details, consult the last page of this installation document.

7 Insert Fixture

- Insert the fixture into the PVC sleeve until it bottoms out on the flat side of the sleeve. Service wire should be pushed down into the internal sleeve volume or customer furnish concrete floor box.
- If the fixture does not sit flush with the finished concrete surface, remove the fixture and trim the PVC sleeve flush using an oscillating multi-tool, then reinstall.

8 Test

- Power on the system to confirm the fixture operates correctly before completing final cleanup.

For Perimeter Concrete Installations:

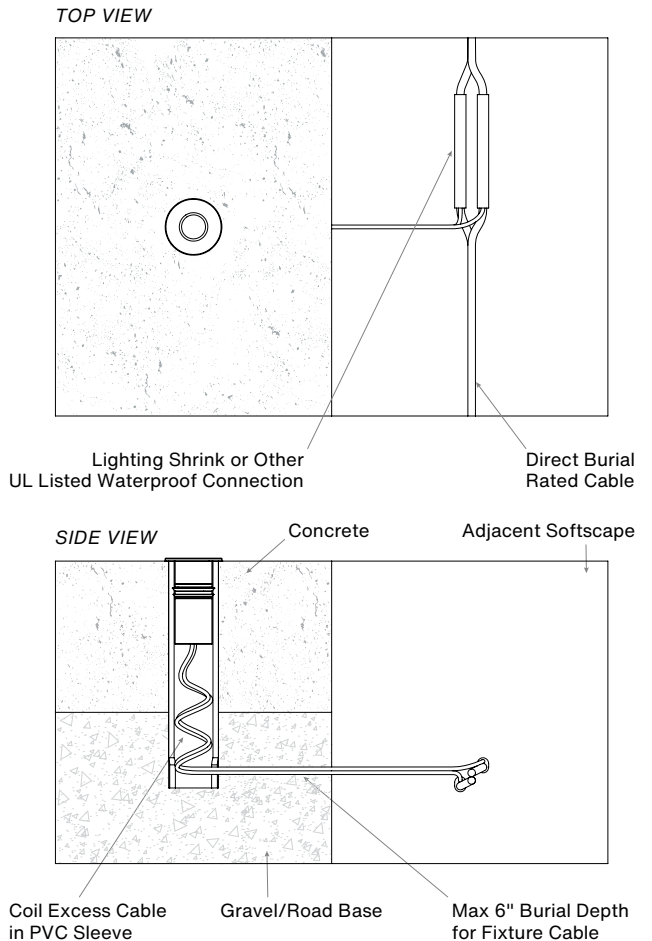

For Interior Concrete Installations:

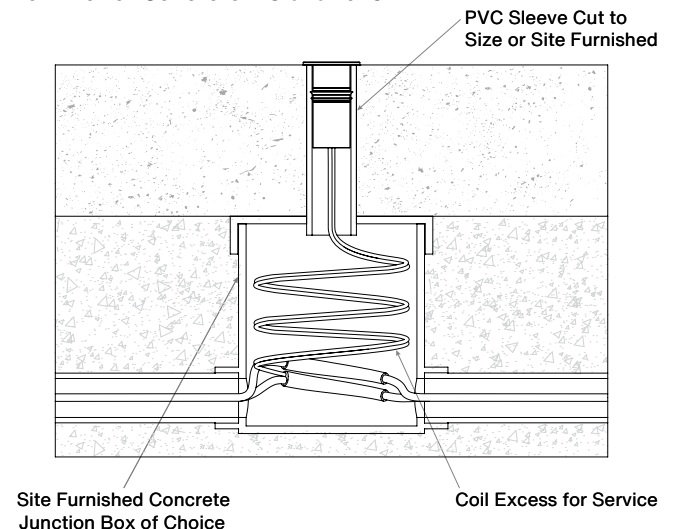

Thin Substrates: For Materials Thinner Than 0.9"

MATERIALS & TOOLS REQUIRED

- ZGLA1 Anchor 1" Step & Marker Light
- LightingShrink® connectors (preferred), or any UL-listed waterproof connector, or installer-preferred method
- Wire strippers
- Heat gun or Torch (for LightingShrink or other heat-shrink style connectors)

1 Prepare Mounting Location

- This installation method is most commonly used for hollow metal extrusions, including pergola post or support members, railing posts, and similar fabricated structures.
- Identify the desired fixture location in the thin wall structure.
- PVC sleeve is not required for thin substrate installations and can be discarded.
- Drill a 1" diameter through-hole using a material-appropriate cutting tool (example: 1" metal hole saw for steel or aluminum). Ensure the hole is perpendicular to the mounting surface.
- Fully deburr the hole to remove sharp edges that could damage wiring.

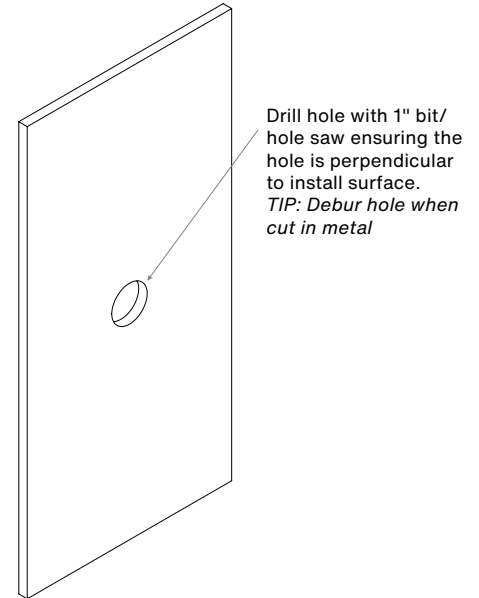

2 Feed Wire

- Route branch wiring through the hollow structure to the fixture location.
- Pull wiring out through the 1" opening, leaving sufficient slack to make splices comfortably outside the structure.

3 Secure PVC Sleeve

- Cut and strip branch wire (input power) and outbound wire (if part of an inline run).
- Strip insulation to 1/2" on each conductor.
- Confirm wire gauge and insulation type are suitable for metal substrates and outdoor use.

4 Make Splice Connections

- Using LightingShrink® connectors (preferred) or other UL Listed waterproof direct burial connectors, splice the fixture wire, branch wire, and outbound wire together.
- After splicing, carefully feed wires back into the hollow structure, taking care not to pinch or abrade insulation against metal edges.

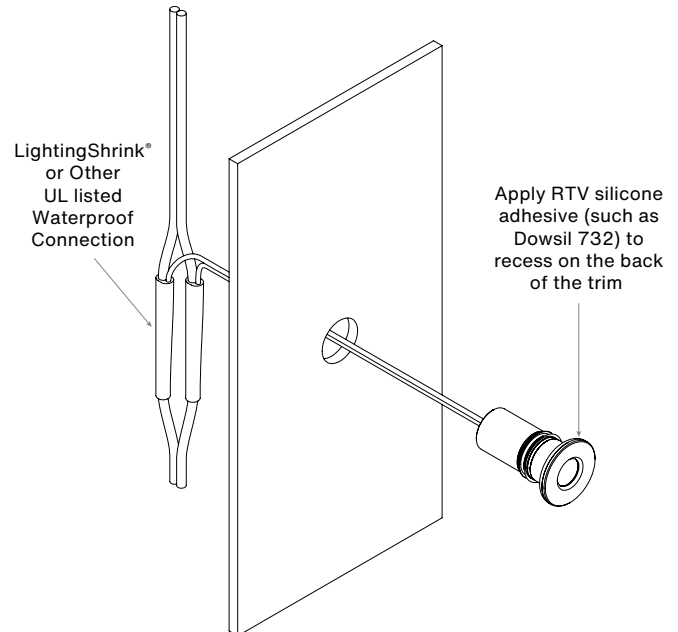

Thin Substrates (Cont.)

5 Insert Fixture

- Prior to inserting the fixture, apply a continuous Bead of exterior-grade RTV silicone (such as Dowsil 732) around the lower lip of the fixture trim.
- Use a small to moderate bead size to minimize excess squeeze-out once installed.
- Firmly press the fixture into the 1" opening until flange is fully seated and flush with the mounting surface.

6 Secure Fixture and Cure Sealant

- Excess RTV silicone will be displaced around the fixture perimeter during installation.
- Clean excess sealant immediately using isopropyl alcohol only. **Do NOT use mineral spirits, paint thinner, acetone, or solvents**, as these will permanently damage the fixture finish.
- Apply painter's tape over the fixture face to hold it flush while the RTV cures.
- Allow sealant to cure per manufacturer's recommended cure time, then remove tape and clean any remaining residue.

7 Test

- Power on the system to confirm the fixture operates correctly before completing final cleanup.

8 Fixture Removal/Service (If Required)

- If fixture removal is required, carefully score the RTV seal around the fixture trim using a utility knife.
- Gently pry the fixture free using a straight-edge screwdriver or utility knife, taking care not to damage the mounting surface.

WARNING: If this product is installed in a building structure where insulation is in contact or adjacent to the fixture, the installer must use Class 2 cable and contact HK Lightning for the appropriate Class 2 (<60W) power supply.

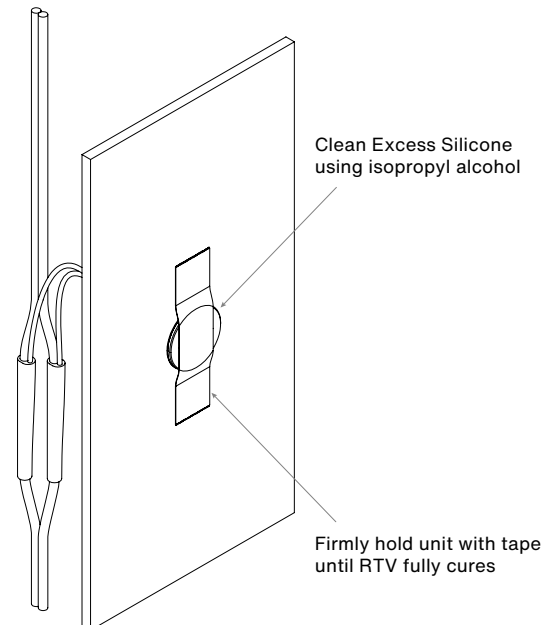
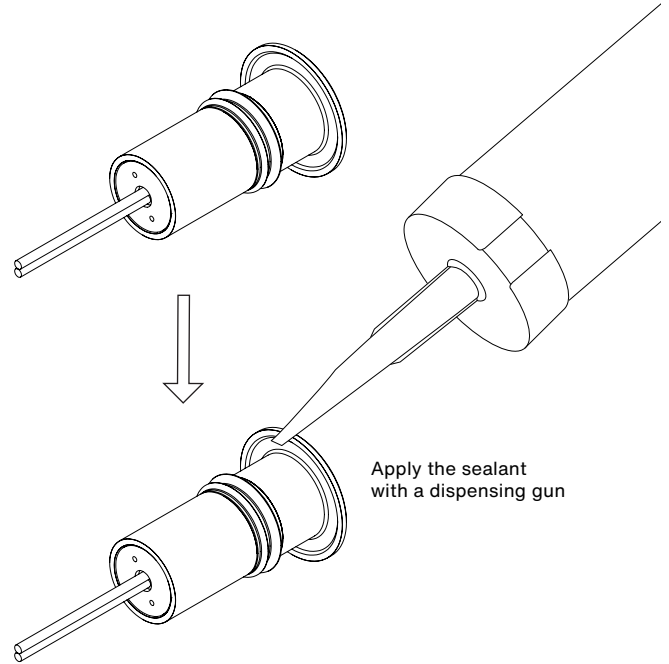

Optic & Optic Accessory Replacement

All ZGLA1 Anchor 1" Step & Marker Lights ship with the specified optic and optic accessory installed. These instructions are only required if you wish to change the optic or add an optic accessory after delivery or installation.

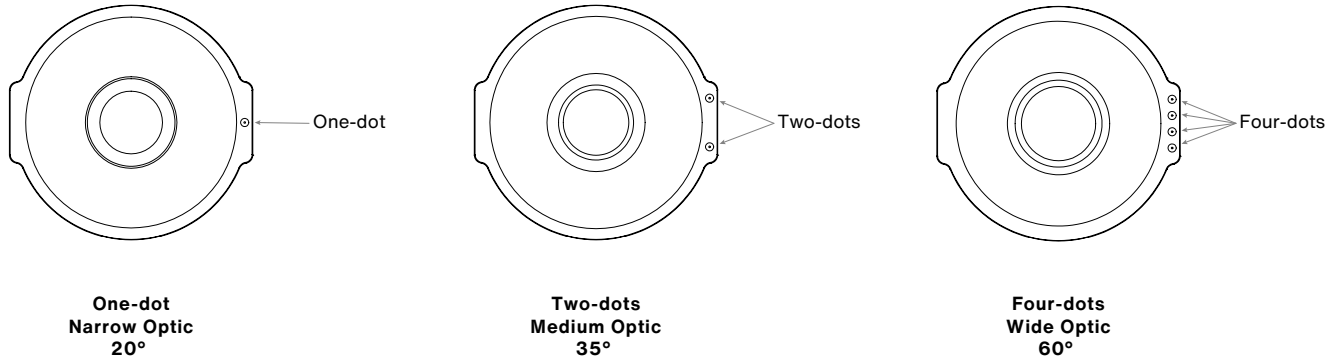

NOTE: Dots are small and can be difficult to see in low light conditions

MATERIALS & TOOLS REQUIRED

- ZGLA1 Anchor 1" Step & Marker Light
- Replacement Optic or Optic Accessory
- Small flathead screwdriver (.06" to .15")
- New disposable glove

NOTE: Always handle optics with clean disposable gloves.

1 Remove Shield

- Rotate the threaded shield counterclockwise to remove and expose the optic.

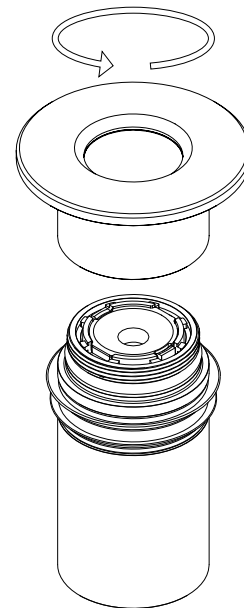

Optic & Optic Accessory Replacement (Cont.)

2 Remove Optic

- Insert a small flathead screwdriver (.06" to .15") under the optic wings.
- Gently pry upward until the optic releases, then remove.

3 Install Optic

- Align the replacement optic.
- Press firmly until it clicks into place and sits flat.

4 Reinstall Shield

- Thread the shield clockwise and hand tighten to maintain watertightness.

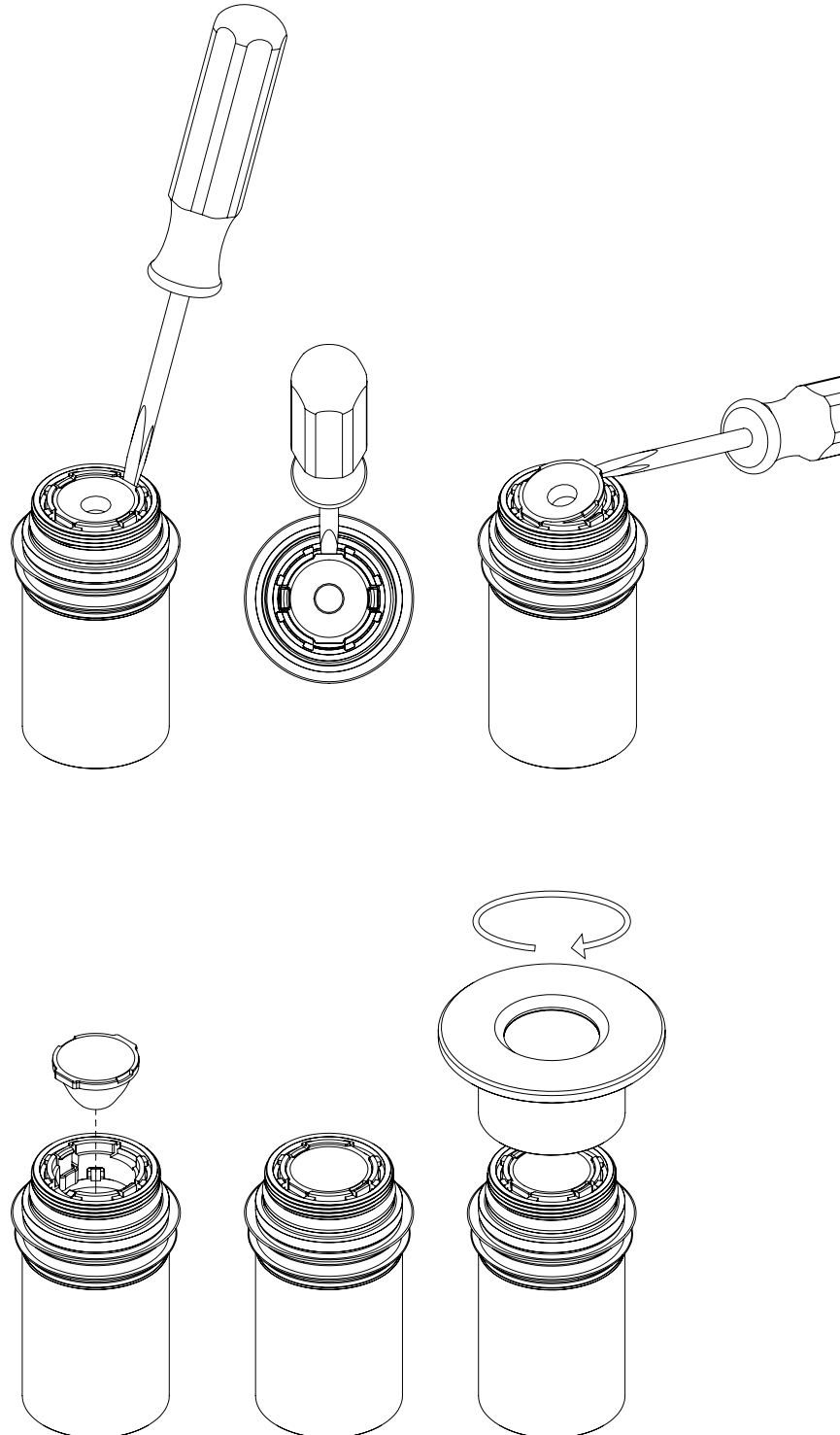

Shield Replacement

All ZGLA1 Anchor 1" Step & Marker Lights ship with the specified optic and optic accessory installed. These instructions are only required if you wish to change the optic or add an optic accessory after delivery or installation.

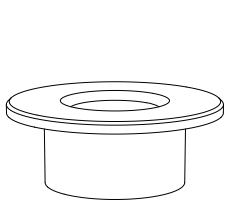

Standard Direct View

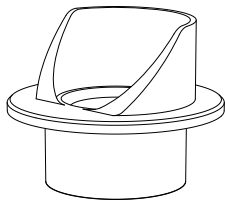

Glare Shield

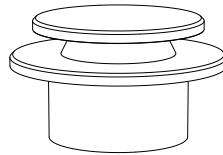

Top Cover 360°

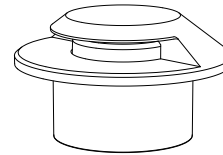

Top Cover 180°

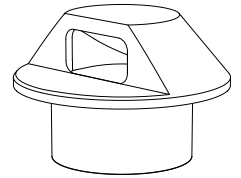

Path/Wall Wash

MATERIALS & TOOLS REQUIRED

- ZGLA1 Anchor 1" Step & Marker Light
- Replacement Shield

To install Standard Direct View and Glare style Shields:

1 Remove Shield

- Rotate the threaded shield counterclockwise to remove and expose the optic.

2 Reinstall New Shield

- Thread the shield clockwise and hand tighten to maintain watertightness.

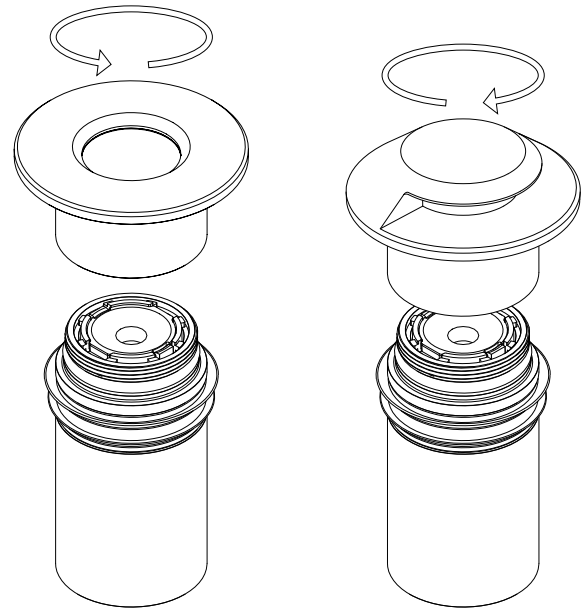

LightingShrink®: Connectors Installation Instruction

MATERIALS & TOOLS REQUIRED

- LightingShrink® connectors (wire splice+shrink tube)
- LightingShrink crimper tool
- Wire strippers
- Heat gun or torch (for LightingShrink or other heat-shrink style connectors)
- Direct burial wire

- 1 Cut and strip wire so 1/2" of copper wire is exposed on both ends.
- 2 Slide black shrink sleeve on one side of wire and insert exposed copper wire into metal crimping connector.
- 3 Use the LightingShrink Crimp Tool tool, select position that matches connector size (blue, yellow or red), and crimp crimp metal connector until Crimp Tool is fully depressed and releases. Crimp both ends of wire to metal connector and check for tightness.

NOTE: If increasing wire thickness is needed fold stripped stranded copper wire back upon itself.

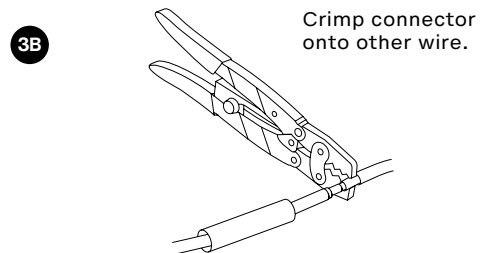
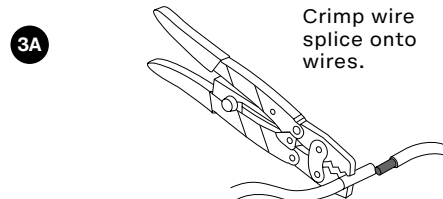
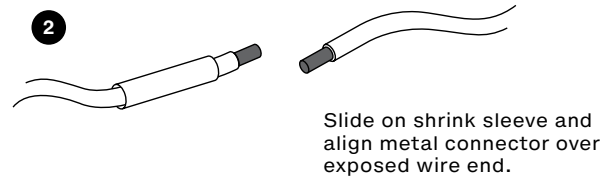
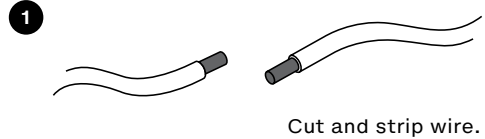

LightingShrink® (Cont.)

- 4 Slide black shrink sleeve over the crimped wire connection. Take care to center the connector in the middle of the shrink wrap tube.
- 5 Lightly heat from center out until protective sealant works out from ends forming a water proof gasket. A professional connection must be heated until $\frac{1}{8}$ " - $\frac{1}{4}$ " of the protective sealant emerges from ends to form a waterproof gasket.

4

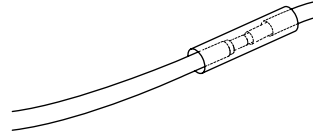

5

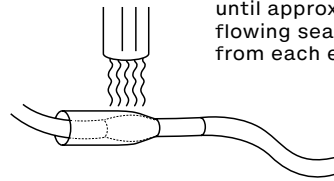

Center LightingShrink over connector and lightly heat until approximately $\frac{1}{4}$ " of flowing sealant emerges from each end.

Available Connector / Sizing Cross Reference

- * **Small (Blue)**
Connects (1) 12 Gauge per barrel/butt end or connects (1) 12 Gauge & (1) 18 Gauge per barrel/butt end.

Medium (Blue)

Connects (1) 12 Gauge & (1) 10 Gauge per barrel/butt end or connects (2) 10 Gauge per barrel/butt end.

Large (Red)

Connects (1) 8 Gauge & (1) 10 Gauge per barrel/butt end.

*

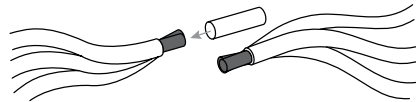

For multiple wire installations, select the appropriate LightingShrink® Connector size and follow the same instructions.